

# Whatever the weather



'March comes in like a lion and out like a lamb' tells of the change from winter to spring

'March winds and April showers, bring forth May flowers'

Many cultures tell of March borrowing 3 days from April and so the first 3 days of April can be wild:

'The first o' them was wind and weet  
The second o' them was snaw and sleet

The third o' them was sic a freeze  
It froze the birds' nebs to the trees'

There are lots of old sayings about the weather. Do your parents or grandparents know any more?

Here are some activities to enjoy whatever the weather – at this time of year especially, there can be all sorts even in one day!

1. For a windy day – **Fly a Paper Bag Kite**
2. For a sunny day – **Build a human sundial**
3. For a rainy day – **Catch and measure the rain**  
More ideas at <https://mothernatured.com/nature-play/50-ways-to-play-in-the-rain/>
4. **Sow some seeds and watch them grow** – making the most of the March winds and April showers (and sunshine)
5. For a cold (grey!) day – **Make Potato Soup and Baking Powder Rolls.** (In the days that March borrows from April, some warming soup and bread might be just the thing!)

# Fly a Paper Bag Kite

March is known for its winds. On a windy day make this simple paper bag kite and then have fun outside catching the wind. (Works on a non-windy day too!)

## You will need:

- **A paper bag** – lunch bag type ideal, but any will work, stronger the better. Plastic bags will work too.
- **String or twine**
- **A stick/loo roll tube - optional**
- **Felt pens/crayons/tissue paper/stickers/colourful plastic bags**
- **(tape)**

## What to do:

Decorate your bag in any way you like - with patterns, a face etc (the open end is the bottom).

Attach streamers cut from tissue/plastic bags to the bottom of the bag.

Fold 3 cm of the open end of the bag over to add strength.

Attach 2 pieces of string/twine about 80 cm long to bag corners by either taping (as in diagram) or threading through holes (as in picture) to form 2 loops.

Cut another longer length of string and tie the 2 loops together. If wish, attach stick/squashed loo roll tube to end of string and wind up to make handle.

Go out and fly your kite – you will need to run with it or stay on spot and spin round to catch the wind.

### MAKE A PAPER BAG KITE:

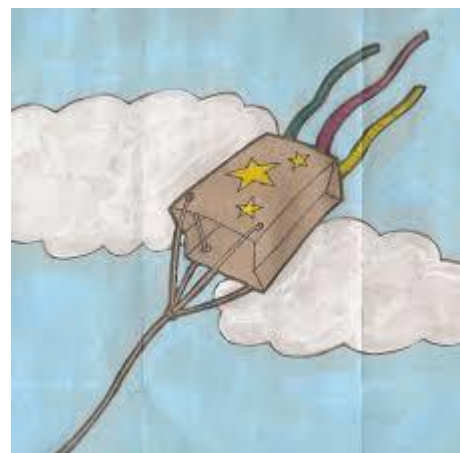
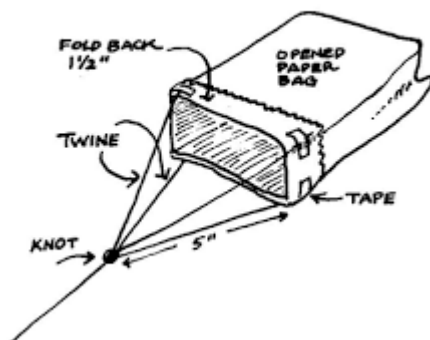

# Build a Human Sundial

## You will need:

- A sunny area
- a slab or tile
- about 12 small stones or tiles
- a permanent marker pen



## What to do:

Start at midday on a sunny day

Put your slab/tile down in your sunny area

Stand on it, straight and tall (you are now the gnomon – the pointy up bit on a sundial!)

Look at your shadow Place a stone (or ask someone else to do it for you) where the top of your shadow reaches. This is 12 o'clock. Write 12 on the stone.

Now set a timer for 1 o'clock and repeat this 1 o'clock. Continue this on the hour every hour until the sun goes down.

Next morning, if the sun is still shining, you can get up early and mark the morning hours.

When you are finished you will have roughly a semi-circle pattern of stones forming your very own human sundial.

## For younger children – have fun with shadows

(think about where is your shadow compared to the sun?)

- Try to run away from your shadow
- Try to jump on someone else's shadow
- Make a the biggest/smallest shadow you can
- Join with someone else to make different shapes
- Compare shadows with other people's or your own at different times of day – do some measuring
- Draw round shadows with chalk

# Catch and Measure the Rain

## What you need:

- A plastic (soft drink) bottle
- Some stones or pebbles
- Tape
- Marker (permanent pen)
- A ruler

## What to do:

1. Ask an adult to help cut the top off the bottle.
2. Place some stones in the bottom of the bottle. Turn the top upside down and tape it to the bottle.
3. Use a ruler and marker pen to make a scale on the bottle.
4. Pour water into the bottle until it reaches the bottom strip on the scale. Congratulations, you have finished your rain gauge.
5. Put your rain gauge outside, in the open, where it can collect water when it starts raining. After a rain shower has finished, check to see how far up the scale the water has risen.

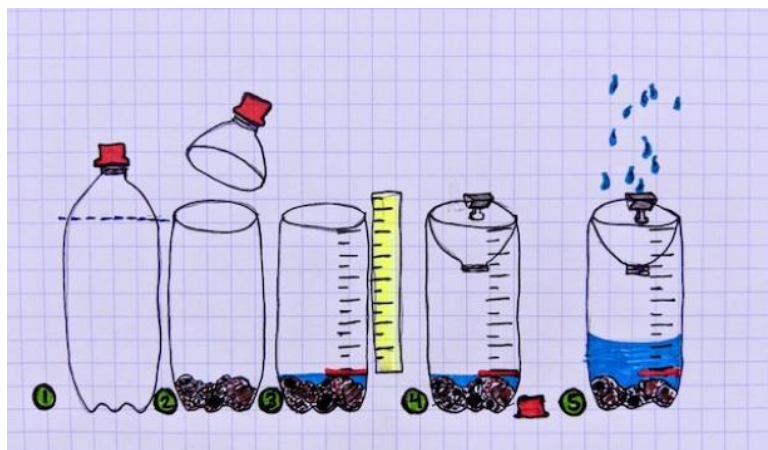

## What's happening?

Rain falls into the top of the gauge and collects at the bottom, where it can be easily measured. Try comparing the amount of rain to the length of time the shower lasted, was it a short and heavy rain shower or a long and light one?

If you want to get serious you can graph the rainfall over weeks or even months, this is especially interesting if the place you live experiences varying seasons where sometimes it is very dry and other times it is very wet.

**Alternatively (for younger children)** – Put out in the rain a selection of different sized and shaped containers and watch how they fill.

# Sow some seeds and watch them grow

## You will need:

- toilet roll tubes
- scissors
- A plastic tub
- Compost or soil
- Seeds  
(whatever you have even from an apple!)



## What to do:

1. Cut 2 cm slits around the bottom of the toilet tubes. Fold these inwards to make a small plant pot.
2. Place these in the plastic tub.
3. Fill each with compost or soil, to 1 cm from the top.
4. Water the compost until damp.
5. Place in your seeds – only one in each if something large or a few if small seeds.
6. Cover with more compost or soil and place on a window-sill.
7. Water the seeds every few days to keep the compost damp.
8. In a few days your seedling should appear.
9. Once they are a few centimetres tall and the weather is warmer you can plant outside, pot and all as it will compost!

If you have no seeds, try placing a carrot top in a saucer with a little water and see if some leaves will grow from it. You will need to keep it moist (You will not get any carrots!)

## Potato Soup

2 tabsp vegetable oil  
1 onion, chopped finely  
1 carrot, grated  
600gms potatoes, diced  
½ teasp mixed herbs  
1/4 teasp salt  
750 ml vegetable stock



1. Wash and prepare all vegetables.
2. Heat oil in large pan and cook onions until soft.
3. Add potatoes and carrots.
4. Add stock, salt and mixed herbs.
5. Bring to boil and simmer for 30 minutes.
6. When cooked blend until smooth if wished.

## Baking Powder Rolls

100 g SR flour  
100g wholemeal flour  
1 tsp baking powder  
¼ tsp salt  
25g margarine  
125 ml milk

Sieve flours, baking powder and salt into a bowl  
Rub in margarine using fingertips until like breadcrumbs  
Add milk and mix to make a soft dough  
Divide into 4 or 8 pieces and shape into rolls  
Place on a greased tray, glaze with milk.  
Bake at 200c for 10 – 15 mins  
Eat as soon as possible (though doubt there will be any question!)